



# SCARAB SWEEPERS

# ROSMECH

SWEEPER SALES SERVICE SPARE PARTS CONTRACTING®

**SWEEPERS THAT DON'T COST THE EARTH**



## SCARAB MISTRAL UD CHASSIS

### HEAVY DUTY TRUCK MOUNTED SWEEPER

The Mistral is Scarab's auxiliary-engine powered sweeper, providing a modern alternative for operators who prefer a twin-engined sweeper configuration but who also seek to employ the latest technology and Scarab's renowned sweeping power.

Built on UD chassis 10.4 tonnes and powered by a Cummins QSB 3.3 Tier 3A turbo-charged auxiliary diesel engine coupled to Scarab's proven fluid-drive system, the Mistral is not so much an alternative sweeper as an alternative range of sweepers, designed to cope with every conceivable sweeping situation.

The introduction of the Cummins engine presented an ideal opportunity to conduct a design review of the Mistral. The control system has been upgraded to CANbus 2 and we have added a number of new features further enhancing the Mistral's outstanding record of performance and overall usability.

# SCARAB MISTRAL UD CHASSIS

SWEEPERS THAT DON'T COST THE EARTH



To meet the challenge of continued demand for Scarab's truck-mounted sweepers in the ever-changing market place, we have developed the Mistral auxiliary engined sweeper.

Now users can specify a modern alternative to the traditional auxiliary engined sweeper and a Scarab alternative to our range of single engined sweepers.

The Mistral combines the outstanding sweeping power and versatility that all Scarab users have come to expect. And like all Scarabs, the Mistral utilises our compact and proven hydraulic drive system for ALL sweeping functions.

No gearboxes - clutches or drive belts, just quiet, efficient suction and sweeping performance.

Hopper Void: Two body sizes available. 6.2 m<sup>3</sup> and 7.2 m<sup>3</sup> \*. These translate to effective capacities of 5.5 m<sup>3</sup> and 6.5 m<sup>3</sup>.

Superb sweeping performance with an impressive 3.20 m sweep width.

A separate stainless steel water tank of 900 litre capacity supplies the high-pressure system and also the dust suppression jets on all brushes and suction nozzles. The tank is mounted for superior weight distribution and stability, this is especially of benefit when discharging the hopper payload.

A highly efficient, dynamically balanced, overhead-mounted suction fan provides air movement at a nominal 2.8 m<sup>3</sup>/sec for superb suction performance.

CANbus 2 control system for flexibility of operation and servicing.

Superior build-quality throughout with stainless steel hopper body.

Super-efficient turbo-diesel auxiliary power unit.

Excellent access to all areas for servicing and maintenance activities.

Low in-cab operating noise levels.

\* Subject to model/chassis specification

## MISTRAL KEY FEATURES

Hopper Construction	Stainless Steel
Hopper Voided Volume	6.2 m <sup>3</sup> & 7.2 m <sup>3</sup>
Auxiliary Power Unit	Turbo-charged diesel engine
Sweep Width	3200 mm
Water Tank	900 Litres
Chassis GVW	10.4 tonne
Control System	CANbus Technology
Wander Hose	4 metre
Dust Suppression	On all brushes and suction nozzles

### SWEEP WIDTHS 6.2 m<sup>3</sup> BODY

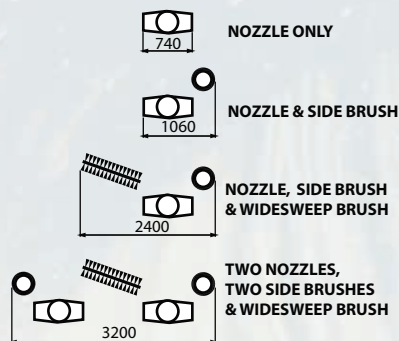

### SWEEP WIDTHS 7.2 m<sup>3</sup> BODY

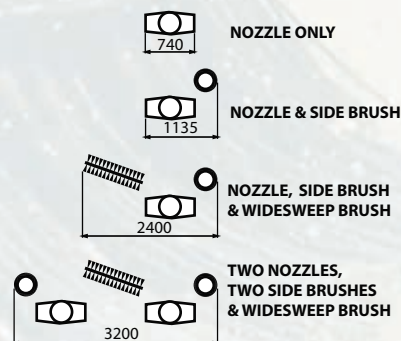

## Scarab Mistral

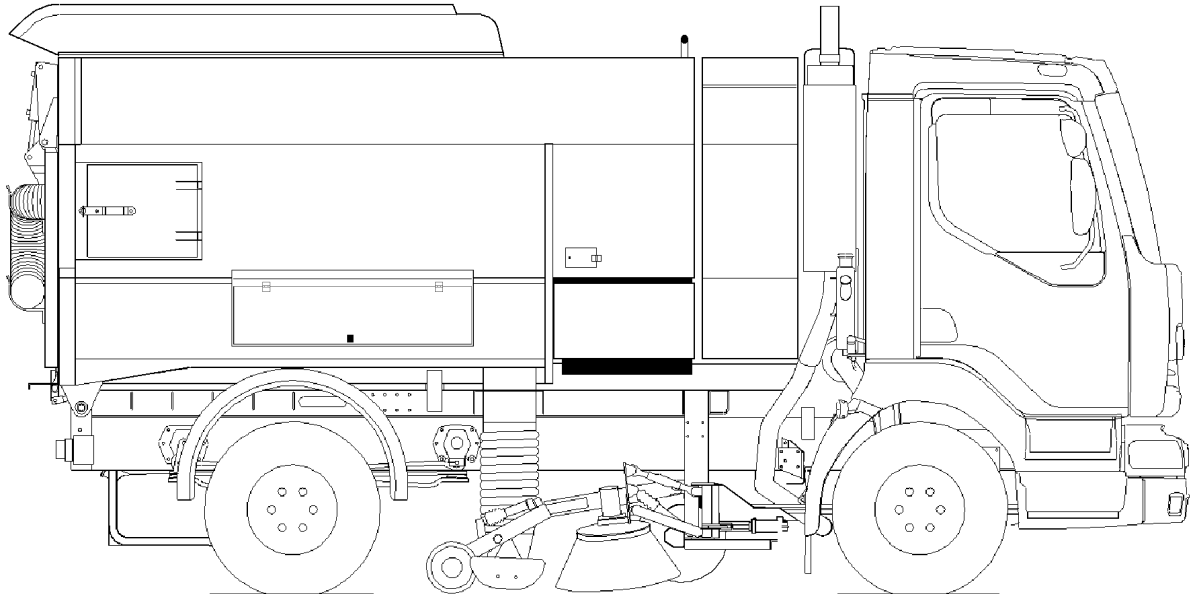

Providing users with the outstanding sweeping power that all Scarab operators have come to expect, the Mistral range has been developed specifically to satisfy a preference for the traditional form of truck-mounted sweeper. The use of a well-proven auxiliary power unit coupled to Scarab's tried and tested hydraulic drive system for ALL sweeping functions has resulted in a twin-engine sweeper for the future. No gearbox - No drive belts; just quiet and supremely efficient suction and sweeping performance.

- **Superb performance with sweeping widths of 2.95 m, 3.2 m or 3.4 m depending upon model selected.**
- **Separate stainless steel water tank, ranging from 900 litres to 2500 litres and mounted for superior weight distribution and stability; especially when discharging.**
- **Highly efficient, overhead-mounted suction fan providing air movement of 2.8 m<sup>3</sup>/sec nominal.**
- **CANbus control system for flexibility of operation and servicing.**
- **Superior build-quality throughout with stainless steel hopper body.**
- **Super-efficient turbocharged auxiliary power unit.**
- **Excellent access to all areas for servicing and maintenance activities.**
- **Extremely low in-cab noise levels.**
- **Available for chassis ranging from 10 to 19 tonne GVW with a choice of three body sizes.**

**AUXILIARY POWER UNIT:** A well-proven turbo-diesel unit coupled to Scarab's unique fluid drive system to power all sweeping functions. The Scarab approach effectively simplifies the sweeping system eliminating the need for complex drive belts arrangements or gearboxes. The auxiliary unit is supplied by a dedicated fuel tank of 115 litres minimum capacity.

**SUCTION FAN:** The dynamically balanced **900 mm diameter suction fan** is mounted in the hopper top and, as with all Scarab sweepers, is powered by a load-sensing pump to give the highest performance and efficiency while minimising noise level. The impellor is a highly efficient multi-blade centrifugal unit, giving a nominal airflow of 6000 ft<sup>3</sup>/min. (170 m<sup>3</sup>/min.).

Mounting the fan on the hopper top creates a virtually straight airflow from the suction nozzles. This makes the Scarab Mistral extremely efficient and significantly reduces power requirements. Two operating modes are provided, **Standard Mode** for normal sweeping and **Boost Mode** which significantly increases suction power for more arduous conditions.

**SUCTION NOZZLE:** Of all-steel construction, the 740 mm wide suction nozzle is mounted in a trailed frame running on 250 mm diameter rubber tyred wheels. The suction nozzle is either 740 mm or 840 mm wide (dependent upon specification) and is fitted with replacable and adjustable rubber flaps and a skid plate. A 250 mm diameter suction hose connects the nozzle to the hopper. Flap to ground clearance is between 25–30 mm resulting in a long flap life and less need for adjustment. Four manually adjustable water spray jets are fitted to the nozzle at 90° intervals to provide an internal dust suppression spray. Additional water injection nozzles are available when required. An optional 4-jet water boost bar can also be fitted in front of suction nozzle for use in extreme conditions. A tilting mechanism, controlled by a pneumatic ram, enables the suction nozzle to accommodate large objects or autumn leaf build-ups with ease.

**SIDE BRUSH:** 500 mm or 650 mm diameter steel-tined quick-change brush (dependent upon specification) with direct drive hydraulic motor, fitted in a trailed linkage with kick-back protection and pneumatic ram for in/out control. The assembly is fully adjustable for brush angle and provides three brush speeds (nominally 100 / 125 / 150 RPM). Optional up/down brush pressure control is available if required. A work light is fitted to assist with low light operation.

**WIDE SWEEP:** Comprising 320 mm or 400 mm diameter (dependent upon specification) replaceable polypropylene segments and powered by a direct-drive hydraulic motor, the assembly is fully-floating, with shock absorbers to prevent bounce, and is fitted in a trailed linkage to ensure parallel, even brush wear. Three brush speeds are provided (nominally 200 / 250 / 300 RPM). Optional up/down brush pressure control is available upon request.

**WATER PUMP:** A self-priming pump fitted with suction filter, driven by a direct-drive hydraulic motor. Solenoid valves operated from the main control panel direct water supply to the brushes and suction nozzles.

**WANDER HOSE:** A lightweight flexible four metre long suction hose of 150 mm diameter, complete with aluminium extension tube and adjustable handle for cleaning awkward areas or gullies. Quick release wander hose points are located at either side of the rear door. The wander hose can be used simultaneously with sweeping or on its own for more powerful suction. Optional rear-mounted overhead boom with aluminium or steel gully entry tube can be fitted if required.

**HOPPER:** Totally constructed from corrosion and abrasion resistant stainless steel, the hopper is fitted with large access doors on either side and a reinforced rear door with heavy-duty seals. The rear door incorporates an automatic closure system which clamps the door at 3 points, for a watertight seal, and body-drain fittings for removal of excess water.

All inlet tubes are fitted with automatic blanking flaps and an easy-to-clean swing-down filter screen is mounted in the top of the hopper immediately below the suction fan. A storage compartment is provided, located on right hand side of the body.

The hopper is tipped by means of a two-stage tipping ram facilitating rapid load discharge. the Mistral Hopper is available in various sizes to suit the required service profile and size of chassis as follows:

GROSS HOPPER VOLUME	PAYLOAD CAPACITY	CHASSIS SUITABILITY
6.2 cubic metres	5.5 cubic metres	10 - 15 tonne
7.2 cubic metres	6.5 cubic metres	13 - 18 tonne
8.5 cubic metres	7.5 cubic metres	18+ tonne

**ACCESS DOORS:** Large doors fitted each side of the hopper for hand-loading bulky items.

**HYDRAULIC SYSTEM:** The hydraulic system comprises one axial piston pump, with automatic control of output and pressure, which drives the suction fan and two gear pumps to provide working pressure for all other hydraulic services. The system is piped in zinc plated steel tubing, where practical, and is protected by 10-micron filters to ensure long component-life. The system's oil is cooled via a heat exchanger with a hydraulically driven high-performance fan, ensuring optimum cooling under the most arduous working conditions and high ambient temperatures. The hydraulic control valves are located for easy servicing in a protected compartment. All hydraulic services, apart from rear door closure can be operated from the in-cab control panels.

**HYDRAULIC TANK:** Located adjacent to the oil cooler, it has a capacity of 15 litres and is equipped with a 10 micron return filter, air breather/filler cap, a suction strainer and a sight glass with automatic low-level shut off.

**PNEUMATIC SYSTEM:** The pneumatic system is connected to the vehicle auxiliary air supply, and is fitted with a pressure regulator, filter/water separator and pneumatic solenoid valves to control the side brush, wide sweep brush and suction nozzle. The pneumatic valves are located for easy servicing in a protected compartment.

**CANbus CONTROL PANEL:** Scarab's tried and tested CANbus system has been in service since 2003 and has proved to be a very successful and welcome innovation. An ergonomically designed panel adjacent to the driver's seat contains all controls for operating the suction fan, brushes, hopper, work lights and water sprays. The panel is also capable of displaying operating data such as Fan speed, Distance and Hours Swept and provides system diagnostics and fault-finding checks on sweeping functions. An additional satellite control box for frequently used operations is mounted conveniently to hand.

**WATER TANK:** Ranging from 900 - 2500 litre capacity (dependent upon specification) and manufactured from corrosion resistant stainless steel. Filling is achieved by means of a hydrant connection with regulation air break, or alternatively by means of hose pipe and special adaptor. The tank is also fitted with a sight-glass / level indicator and suction strainers for the water pumps.

**PAINTING:** Two pack system single colour, optional multi colour and sign-writing.

**SWEEPING WIDTHS:**

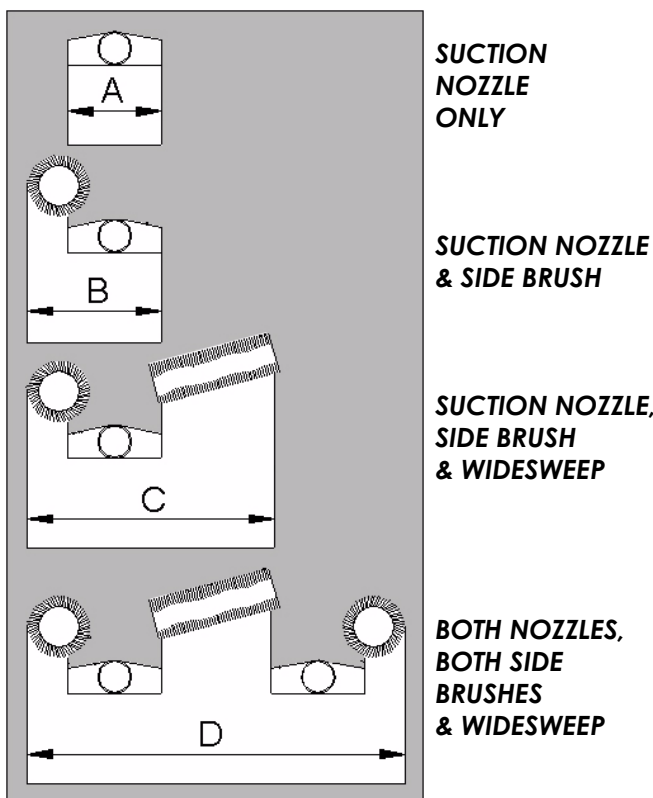

**Sweep Widths in mm**

MODEL	6.2	7.2	8.2
DIM A	740	740	840
DIM B	1060	1135	1235
DIM C	2000	2075	2275
DIM D	2950	3200	3400

On dual sweep machines the Scarab Mistral has the option of operating with both side brushes and nozzles simultaneously to give an unrivalled sweeping width.

The suction nozzle, side brush and wide sweep brush can be raised or lowered independently of each other. This provides various sweeping patterns to suit differing road conditions.

**TYPICAL WEIGHT DATA:**

Scarab equipment weights are:

- Single sweep configuration (including fixed widesweep) - - - - -2180 kg
- Dual Sweep configuration (including swivelling widesweep) - - - - -2340 kg

<b>CHASSIS/MODEL PAYLOAD POTENTIAL</b>	
<b>10/12 tonne chassis with 6.2 cubic metre body</b>	<b>Upto 4000 kg</b>
<b>18+ tonne chassis with 8.2 cubic metre body</b>	<b>Upto 9500 kg</b>
<i>For chassis/model specific payload information please contact the Scarab Sales Department</i>	

**CHASSIS SUITABILITY:**

The Scarab Mistral can be mounted on a range of chassis.  
For details of suitable chassis specifications please contact the Sales Department.

**TYPICAL DIMENSIONAL DATA:**

The following are indicative only. For specific chassis related details please contact the Sales Department.

Length Overall	<b>A</b>	5500 mm
Height Overall	<b>B</b>	2980 mm
Front Overhang	<b>C</b>	1240 mm
Rear Overhang	<b>D</b>	1350 mm
Wheelbase	<b>E</b>	3330 mm
Max Height (Hopper Up)	<b>F</b>	4180 mm

**OPTIONS:**

A comprehensive range of options is available, please contact the Scarab Sales Department for further information.

**Scarab Sweepers** are dedicated to continuous product development and as such we reserve the right to change this specification without prior notice.  
To ensure latest information contact Sales Department.



Pattenden Lane, Marden, Tonbridge, Kent. TN12 9QD  
 Telephone: 01622 831006  
 Fax: 01622 832417  
 E-Mail: [scarab@scarab-sales.com](mailto:scarab@scarab-sales.com)  
 Web Site: [www.scarab-sweepers.com](http://www.scarab-sweepers.com)

# UD TRUCKS

# MK6 *automatic*

## Leaf Suspension

GVM 10,400kg\* GCM 10,400kg\*\*



## Specifications

### ENGINE

**Model:** J08E -TE - a vander engine manufactured for Nissan Diesel  
6 cylinder 4 valves per cylinder, 4 cycle, direct injection, water cooled, in-line diesel engine, Variable nozzle turbocharger with intercooler

**Number of cylinders:** 6 cylinders  
**Bore x stroke:** 112mm x 130mm  
**Total piston displacement:** 7,684 cc  
**Max. output (ISO Net):** 168 kw (228 PS) at 2,500 rpm  
**Max. torque (ISO Net):** 686 N.m (70 kgm) at 1,500 rpm  
**Max. governed speed:** 2,550 rpm  
**Compression ratio:** 18:1  
**Auxiliary brake:** Pneumatically operated Exhaust Brake

### Lubrication System:

Forced feed by gear pump, Flat tube type oil cooler, Full flow and by-pass oil filter with replaceable element, 11 litre capacity

### Air compressor:

Water cooled reciprocating type, single cylinder with dryer and oil mist separator

### Cooling System:

Forced feed by centrifugal water pump, wax pellet type thermostats incorporated with a by-pass, aluminium corrugate fin type radiator with reserve tank and viscous coupling driven 620mm 8 blade cooling fan.

### FUEL AND INTAKE SYSTEM

High pressure electronically controlled common rail fuel injection system  
Replaceable primary and secondary fuel filters  
200lt capacity steel fuel tank with lockable cap (LHS)  
Dry paper element air cleaner  
High mounted RHS air intake snorkel

### EXHAUST AND EMISSION CONTROL SYSTEM

Emission standard - ADR 80/02  
Electronic controlled, selective, cooled EGR  
Under chassis mounted RHS muffler / catalytic converter with horizontal rear facing exhaust discharge under truck

### ELECTRICAL

24 volt, negative ground system  
2 x 12 volt 120 Ah batteries mounted on LHS frame  
24 volt - 90 amp. with built-in IC regulator

### TORQUE CONVERTOR

**Make and Model:** ALLISON TC 221  
One stage, three element , polyphase. Includes standard integral damper with direct drive lock up function  
**Stall torque ratio:** 1.73 : 1

### TRANSMISSION

**Make and model:** ALLISON LCT2500  
Five forward speeds and one reverse. Fully automatic ALLISON Gen4 adaptive shift transmission with primary radiator mounted water to oil cooler and secondary air to oil cooler

Gear ratios:	Gear	Ratio	Gear	Ratio
	1st	3.51	4th	1.00
	2nd	1.90	5th	0.74
	3rd	1.44	Rev	5.09

**Engine PTO opening:** N/A  
**Transmission PTO openings:** LHS and RHS  
**PTO drive gear rating:** 339Nm\* - Independent operation (one opening)  
271Nm\* - Dual operation (each opening)  
\*Torque ratings @ 100% turbine speed

### BRAKES

Air Over Hydraulic (AOH) dual line, internal expanding, leading and trailing shoe type system with 4 channel BOSCH ABS

**Air pressure:** 7.2 - 8.5 kg/cm<sup>2</sup>

	Front	Rear	Total
<b>Drum diameter:</b>	320 mm	320 mm	
<b>Lining area:</b>	1360 cm <sup>2</sup>	1672 cm <sup>2</sup>	3032 cm <sup>2</sup>

Hand operated pneumatically controlled spring park brake acting on drive axle

### STEERING

Recirculating ball screw type steering box with hydraulic power assist  
Adjustable tilt and telescopic type column with steering lock and 460mm wheel

**Variable steering gear ratio:** Between 18.8 : 1 and 16.1 : 1

### WHEELS AND TYRES

**Number and size of tyre:** **Front** - single 235/75R 17.5 132/130M  
**Rear** - dual 235/75R 17.5 132/130M

See Options for alternative tyre size

Pressed steel disc wheel, 1 piece rim, 6.75 x 17.5 131 offset-10TCS, 6 stud  
One spare wheel and tyre mounted on carrier (STC) at the rear of chassis

### AXLES

**FRONT** **NISSAN DIESEL FA35**  
Drop forged steel "I" section beam, reverse "ELLIOT" type  
**Front axle capacity:** 3,700 kg \*Refer to Load Rating summary for max permissible load

**REAR** **NISSAN DIESEL RS55**  
Fully floating pressed steel banjo type housing, single drive type  
**Final reduction gear:** Single reduction, hypoid gear  
**Final reduction gear ratio:** 4.111  
**Rear axle capacity:** 7,500 kg \*Refer to Load Rating summary for max permissible load

### SUSPENSION

**FRONT**  
Taper leaf spring with anchor at front and shackle at rear  
**Width x length:** 70 x 1,300 mm  
**The number of leaves:** 3  
**Spring constant:** 264N/mm (26.9 kg/mm)  
**Shock absorbers:** Telescopic double acting

**REAR**  
Semi-elliptic leaf spring and helper with anchor at front and shackle rear  
**Width x length:** Main: 70 x 1300mm Helper: 70 x 980mm  
**The number of leaves:** Main: 7 Helper: 7  
**Spring constant (Total):** 985 N/mm (100.4 kg/mm)  
**Shock absorbers:** Telescopic double acting

### LOAD CAPACITY SUMMARY

	235/75R 17.5 tyres		225/90R 17.5 tyres	
	Front(kg)	Rear(kg)	Front(kg)	Rear(kg)
<b>Axle capacity</b>	3700	7500	3700	7500
<b>Steering / Suspension Capacity</b>	3600	7500	3600	7500
<b>Tyre capacity</b>	3700	7500	3600	6800
<b>Max capacity (limit kg)*</b>	3600	7500	3600	6800

Note: Based on nominated tyres and standard springs

# MK6 *automatic* Leaf Suspension

## CAB

Forward control, spring suspended cab with shock absorbers  
Torsion bar cab tilt system  
Front opening inspection bonnet  
Air dam front bumper

### Standard Equipment

Overhead console with driver and passenger sunvisors  
24v Cigarette lighter / power supply with 2 ash trays  
Large On/Off/Door interior light  
Double arm, 2-spnd wipers with intermittent operation and windscreen washers  
LH and RH split mirrors (Flat / Spot)  
LH down spot mirror  
Electric horn, reverse warning light and alarm  
3 occupant seats - 2 outer seats with retractable seat belts and a flat folding centre seat with adjustable lap belt.  
Multi adjustable air suspended driver's seat  
ADR42/04 compliant sleeper bunk with mattress (Stationary sleeping only)  
Sleeper cab curtain rails with curtains  
Power operated driver and passenger windows  
Remote operated keyless central locking  
Multi speed air conditioning  
AM/FM radio with CD player  
Cruise control - Stalk mounted  
Halogen multi reflector headlamps  
Front bumper mounted (ADR49/00) integrated driving lights  
Roof mounted clearance lights (ADR49/00)  
2 centre dashmounted cup holders  
3 DIN sized compartments for accessory fitment

## FRAME

Ladder, Channel type chassis construction

**Width:** 860mm

**Height x width x thickness:** 234 x 70 x 7 mm

**Material:** Pressed carbon steel

Tensile	Yield	Modulus
45kg/mm <sup>2</sup>	30kg/mm <sup>2</sup>	Refer body manual

## INSTRUMENTS

Dash design integrates an array of instruments, warning / informational lights and audible tones

## FACTORY OPTIONAL EQUIPMENT (Indent order only)

Paint colours  
Multi leaf front springs 244N / mm (24.9 kg/mm) – 3800kg Capacity  
Front stabilizer bar  
Large centre console (Replaces centre seat)  
Electronic engine governor control  
Electronic transmission PTO control  
225/90R 17.5 tyres - (6.00 x 17.5 - 135mm offset 10TCS 6stud)  
- with 4.333 diff  
ADR65/00 100km/h speed limiter - Dealer fit Option  
Rear Engine PTO (225Nm @ 100% engine speed continuous operation) - Dealer fit Option  
Rear Engine PTO (343Nm @ 72% engine speed continuous operation) - Dealer fit Option  
Additional transmission cooling package for GCM and heavy duty applications (Compactor, Street Sweeper, etc)

## PERFORMANCE (Calculated)

**Max. speed:**

**Gradeability 1st gear (Calculated):**

**Gradeability 5th gear (Calculated):**

**Est. RPM @ 100km/h:**

**4.111 diff ratio  
with 235/75R 17.5 tyres**

N/A

25.7% @ 10,400kg and 85% convertor efficiency

4% @ 10,400kg

2119rpm

**4.333 diff ratio  
with 225/90R 17.5 tyres**

N/A

25.2% @ 10,400kg and 85% convertor efficiency

3.8% @ 10,400kg

2298rpm

## GENERAL SPECIFICATIONS (approx.)

Wheel Base	Weight (kg)				
	GVM*	GCM**	FA <sup>1</sup>	RA <sup>1</sup>	Total Tare <sup>1</sup>
<b>E</b>	10400	10400	2215	1170	3385
<b>F</b>	10400	10400	2225	1180	3405
<b>K</b>	10400	10400	2245	1200	3445

Dimensions (mm)												
WB	OL	OW	OH <sup>2</sup>	FT	RT	ROH	CA	GC <sup>2</sup>	FHF <sup>2</sup>	FHR <sup>2</sup>	Turn Radius Kerb to Kerb	
3770	6665	2200	2515	1780	1675	1620	2740	185	730	850	5990	
4230	7335	2200	2515	1780	1675	1830	3200	185	730	850	6720	
4830	8235	2200	2515	1780	1675	2130	3800	185	730	850	7670	

<sup>1</sup>Weight estimated including fluids (not fuel) and STC and spare wheel, excludes tools and driver. <sup>2</sup>Based on vehicle with standard 235/75R 17.5 front and rear tyres. Add 23mm for 225/90R17.5 tyres.

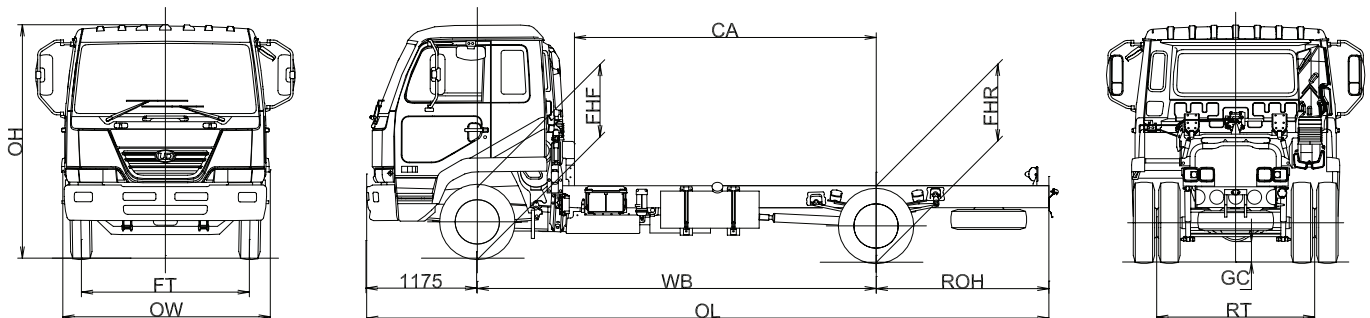

Imported and distributed by Volvo Commercial Vehicles Australia (ABN: 27 000 761 259)

Photos for illustration purposes.

Volvo Commercial Vehicles Australia reserves the right to modify design and change equipment without previous notification.

Please Consult with UD Trucks dealer for the latest information about vehicle specification.

\*Rated GVM for on highway applications only. See Options for additional transmission cooling package for heavy duty applications.

Rated GVM and axle capacities are subject to Federal, State and Territory legal requirements.

\*\*GCM up to 14,900kg on engineering application, see your UD Trucks dealer.

